

Soil Compaction

What is it and how can we prevent or remediate it?

LARGE PORES

SMALL PORES

x mm

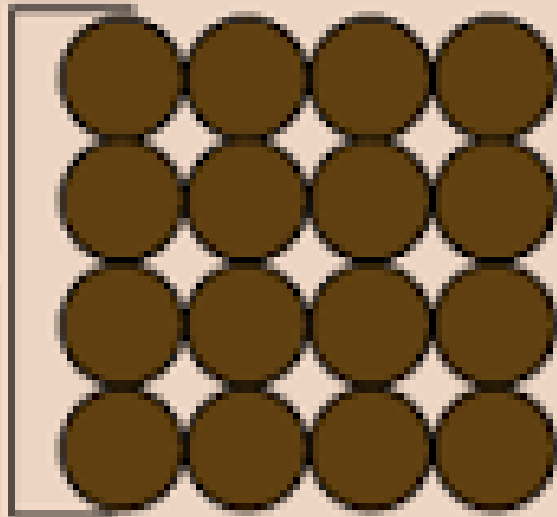

Non compacted particle arrangement.

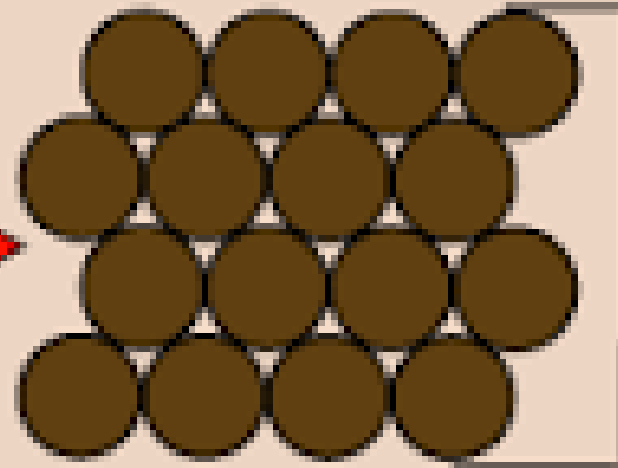

$< x$ mm

Compacted particle arrangement.

Uncompacted soil absorbs water and support
plant growth



12.28.2015 22:25





Soil Compaction

Field observations of compaction:
ponded water,
surface crust,
discolored or poor plant growth and
eroded soil with stone caps
remaining.









11/24/2015





Why do we care about Soil Compaction?

- Soil compaction reduces stormwater infiltration and increases stormwater runoff
- Increased run-off accelerates soil erosion and sedimentation
- Flooding
- Loss of groundwater resources























What is soil and how is compacted soil different?

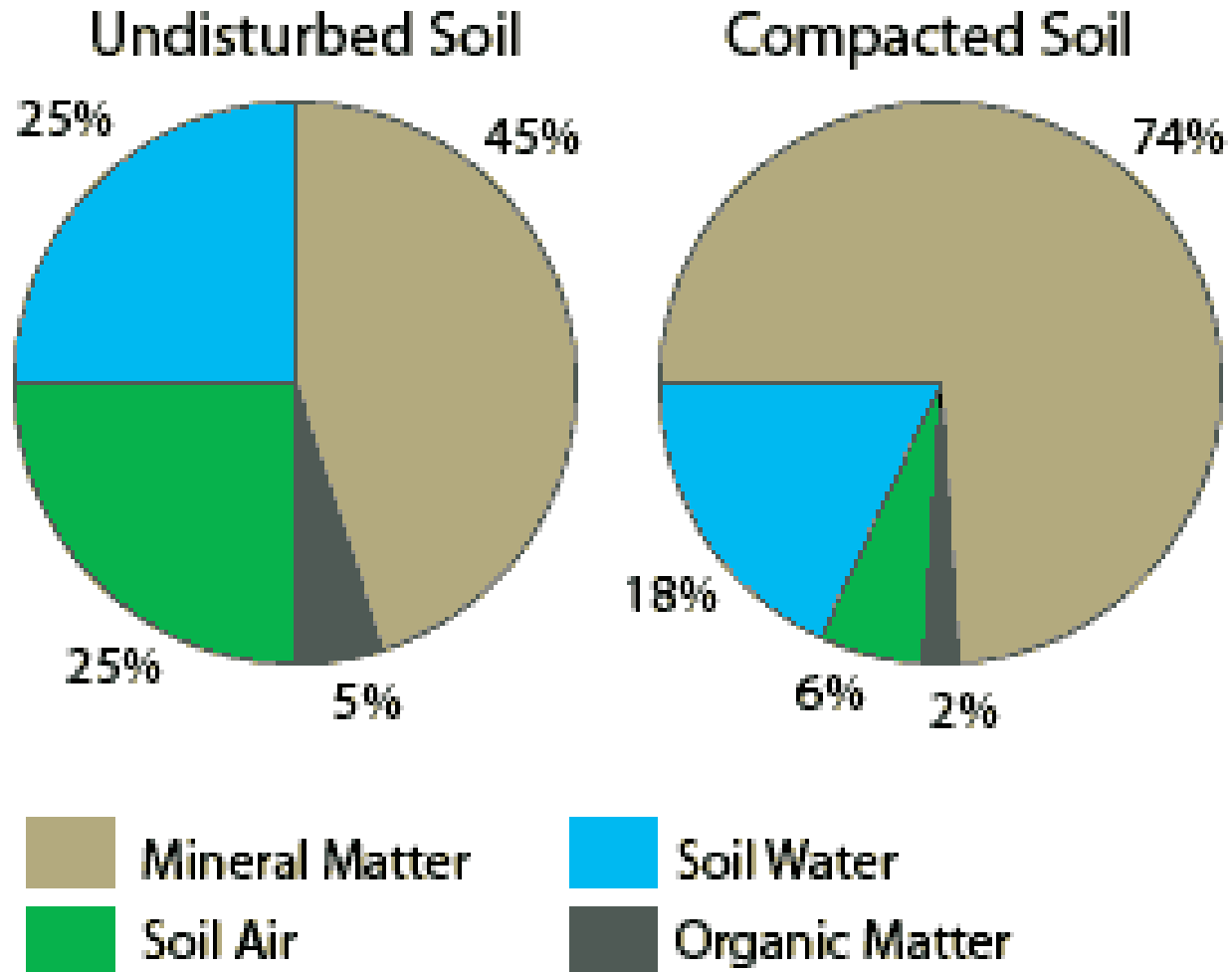

Sand, Silt, and Clay

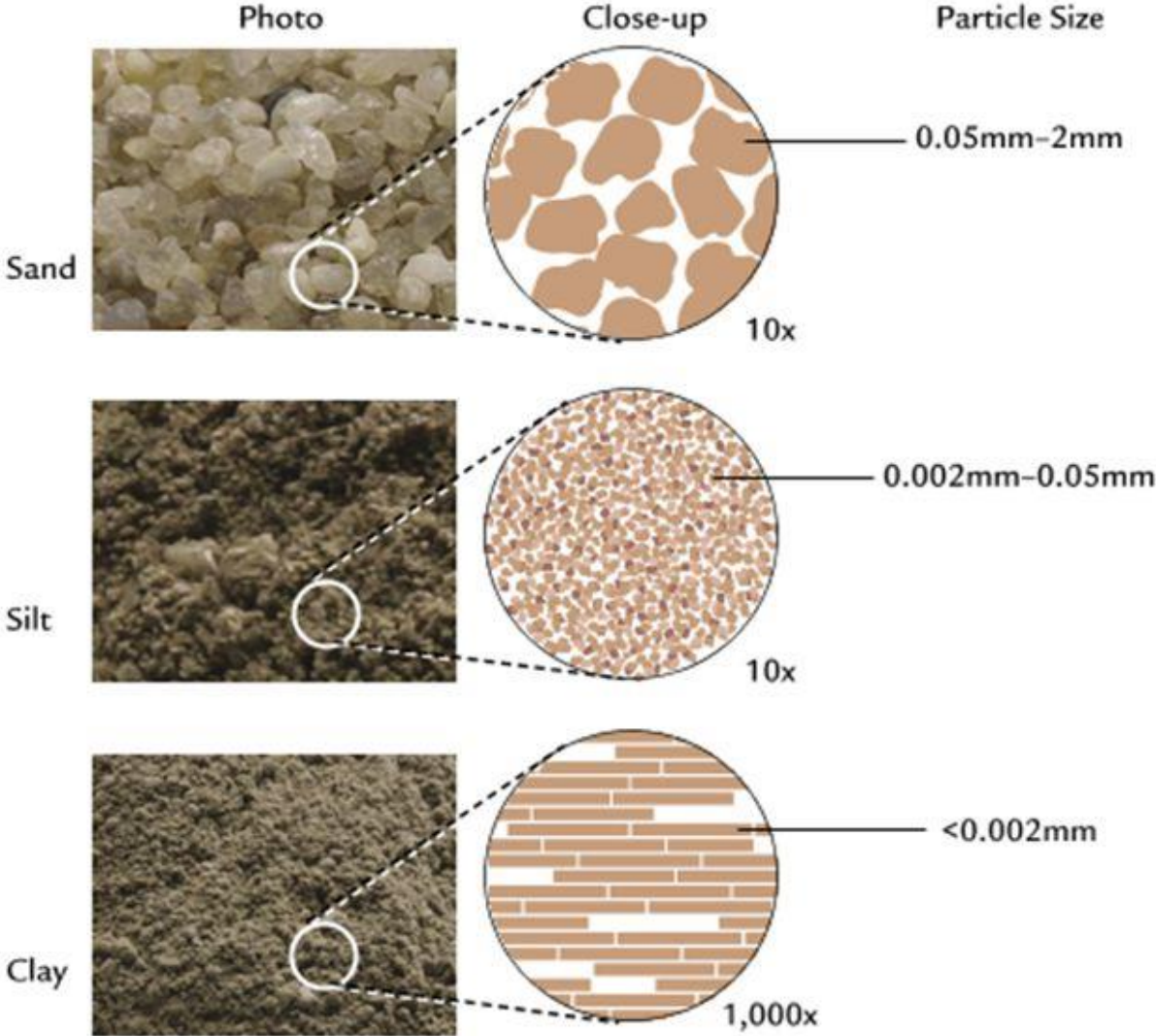



Clay

Silt

Sand

GRANULAR

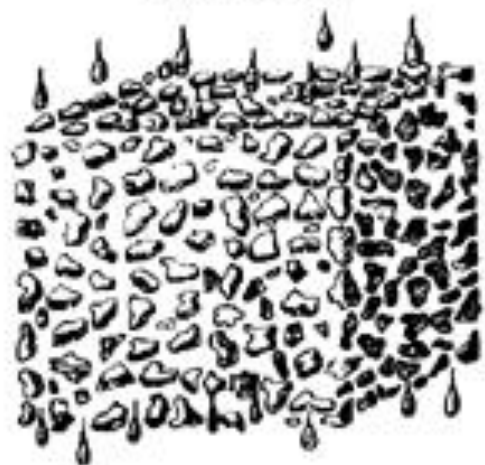

PRISMATIC



MASSIVE

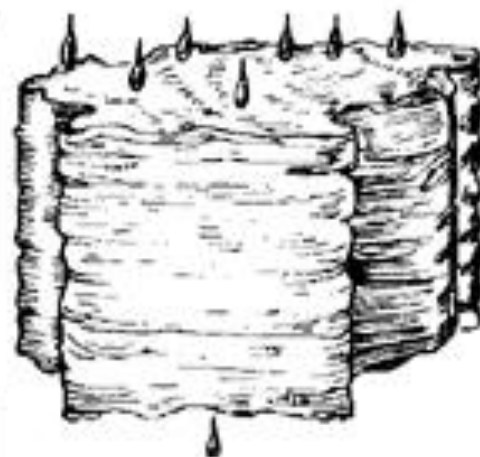

SINGLE GRAIN



BLOCKY



PLATY



RAPID

MODERATE

SLOW

Soil Structure



Granular



Blocky



Platy



Massive



Single grain

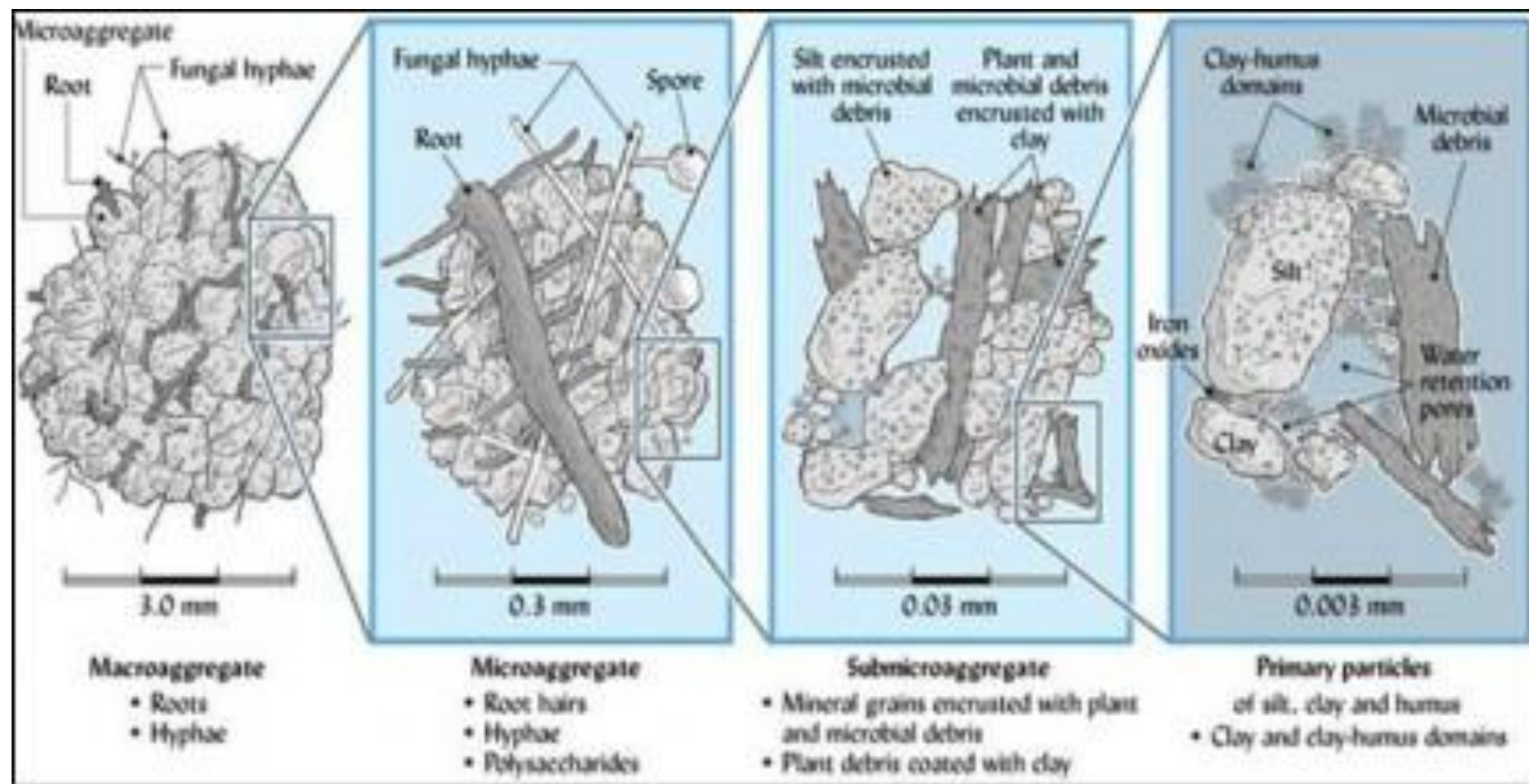

a. Well-structured soil

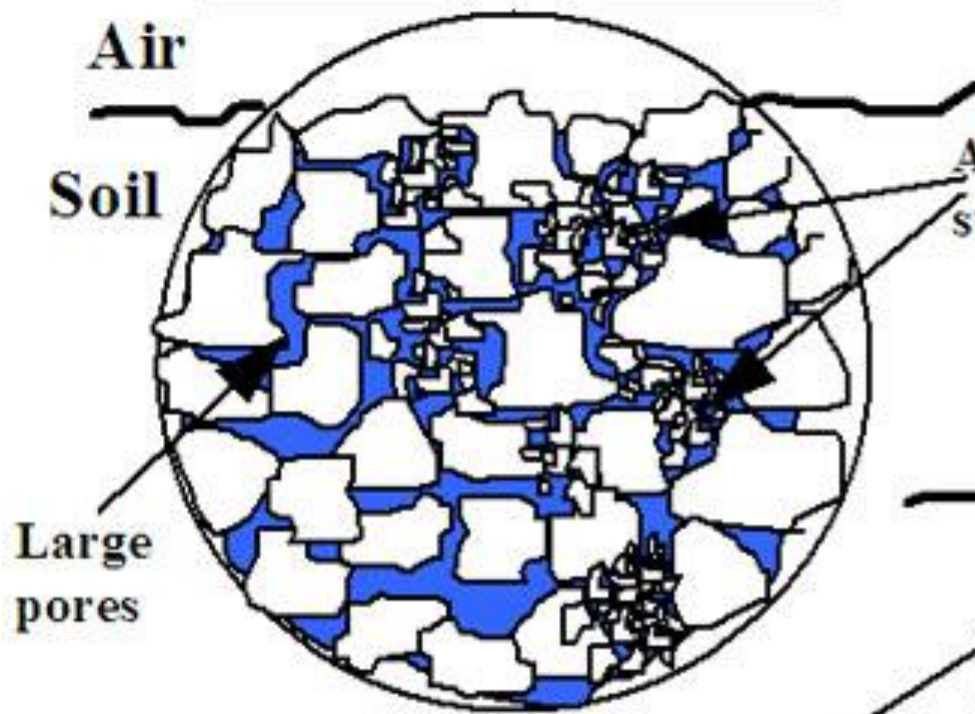

b. Poorly structured soil

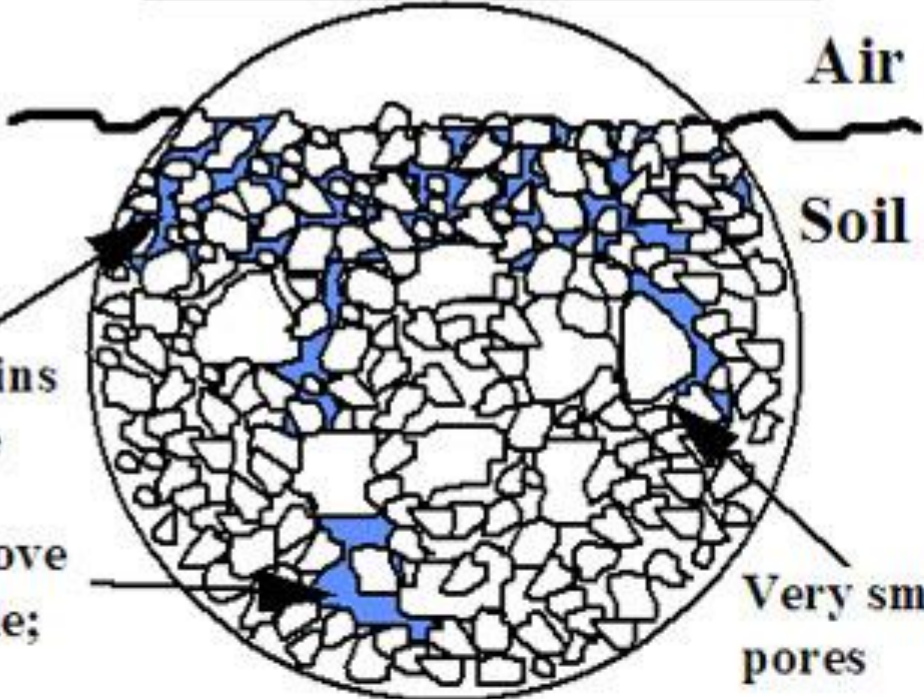

Water and nutrients move very slowly down profile; air may be excluded

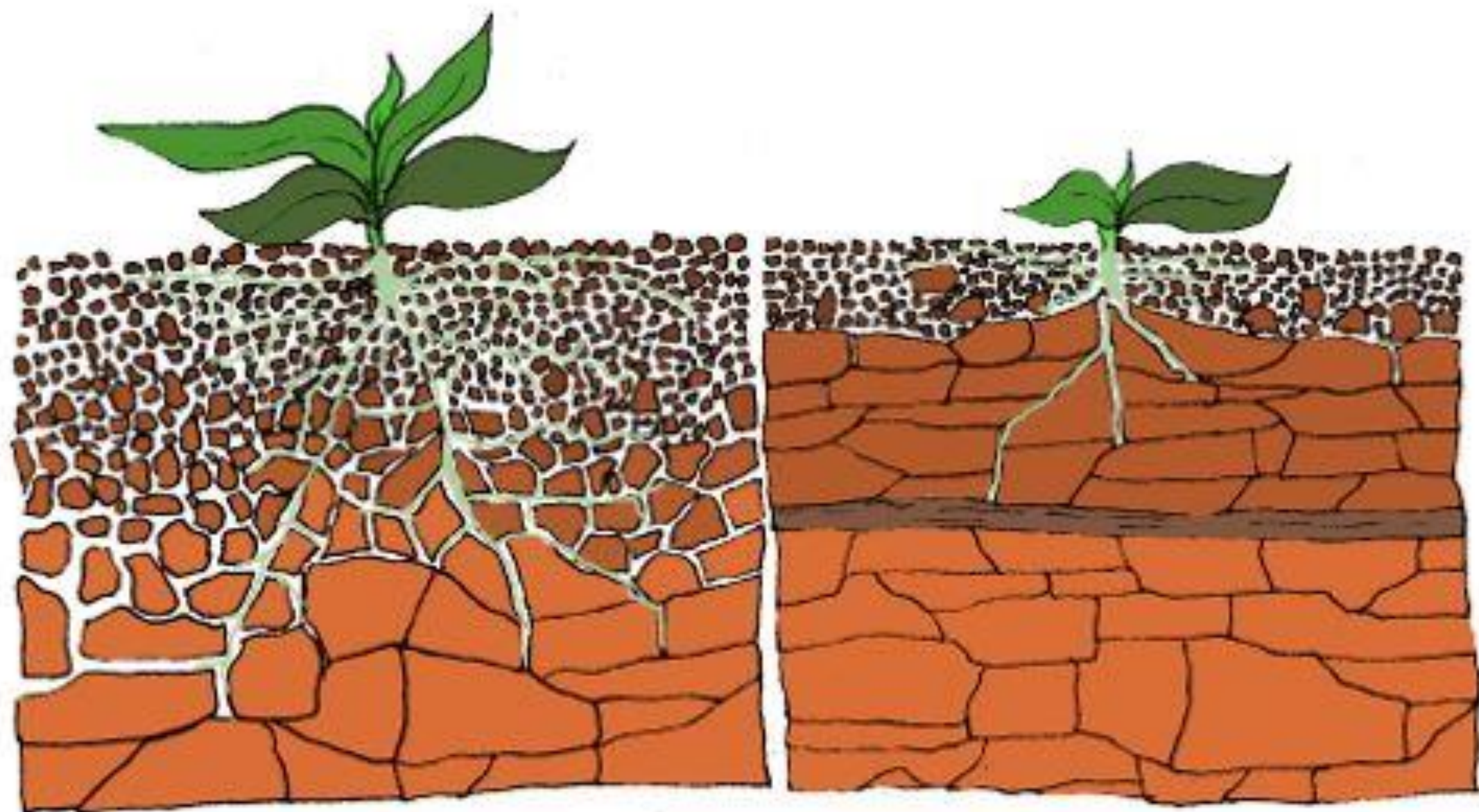



Bulk Density of a Soil is the Weight of the Soil per Unit Volume.

Compacted soil has a higher bulk density because there is less open space, or pores which hold air and water.

Cone Penetrometer



Soils with a high bulk density have lower water infiltration rates.

There are less open pores for the water to be stored and drain through.

Bulk Density – an estimate of the amount of soil compaction

- Undisturbed Soil 0.8 – 1.2 Mg/m³
- Increase in Bulk Density with Disturbance
 - Crops 0.25 – 0.35
 - Construction, no grading 0.20
 - Construction, mass grading 0.35
 - Construction traffic 0.17 -0.40
 - Urban lawn 0.30 – 0.40
- Roots inhibited 1.47 – 1.65
- Infiltration not adequate 1.65

Double Ring Infiltrometer Test



Field Capacity

- Soils that are at or below field capacity are not saturated and have the larger pores free from water.
- Soils below field capacity are more resistant to compaction
- Below field capacity, the soil will be firmer and leave an uneven, thin coat of mud on your hands.
- A ball of silt loam above field capacity shows free water on the surface when squeezed. Leaves a continuous mud film on hands.

Surface Compaction



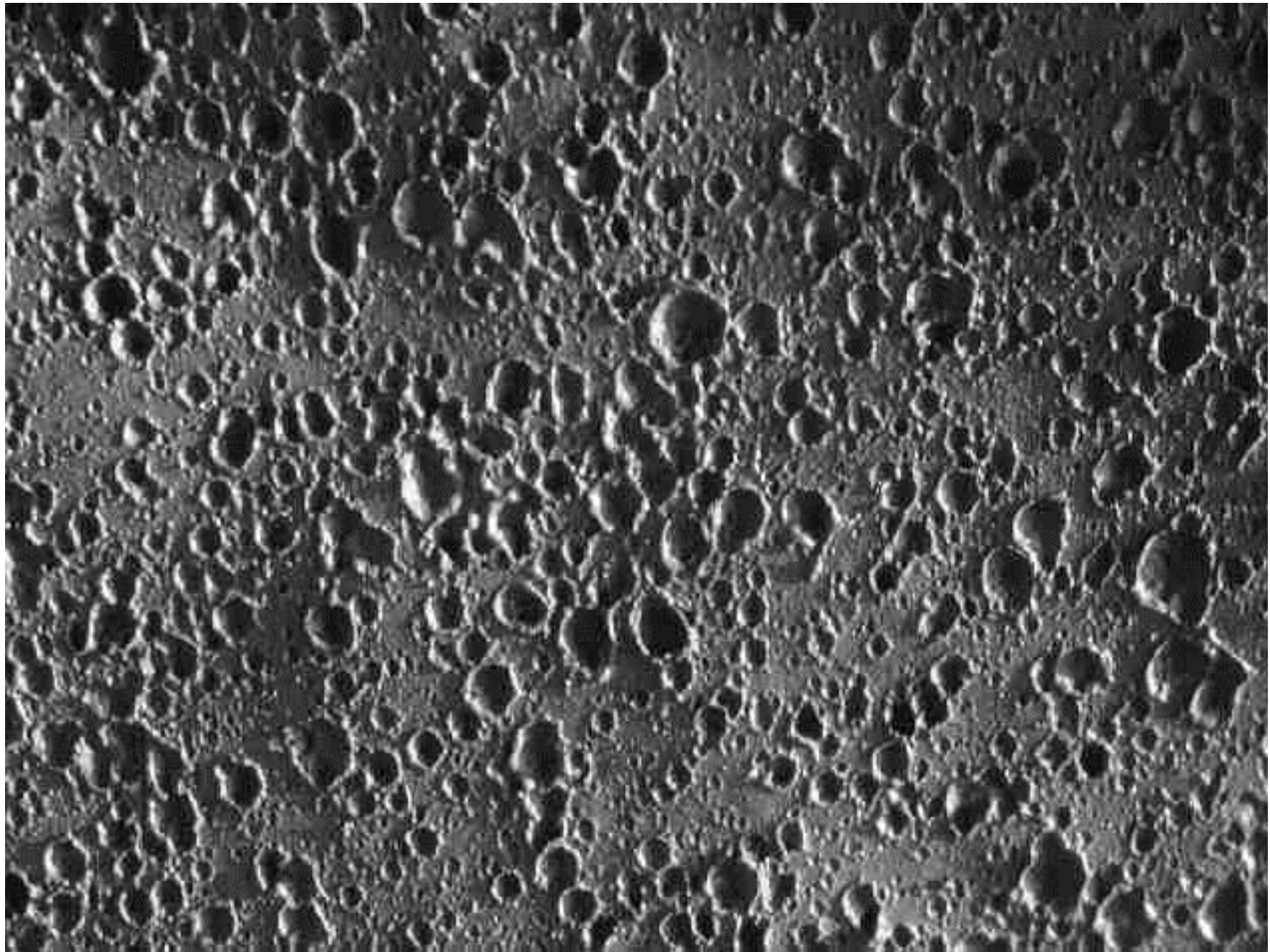



Changes in water flow due to soil crusting/compaction.

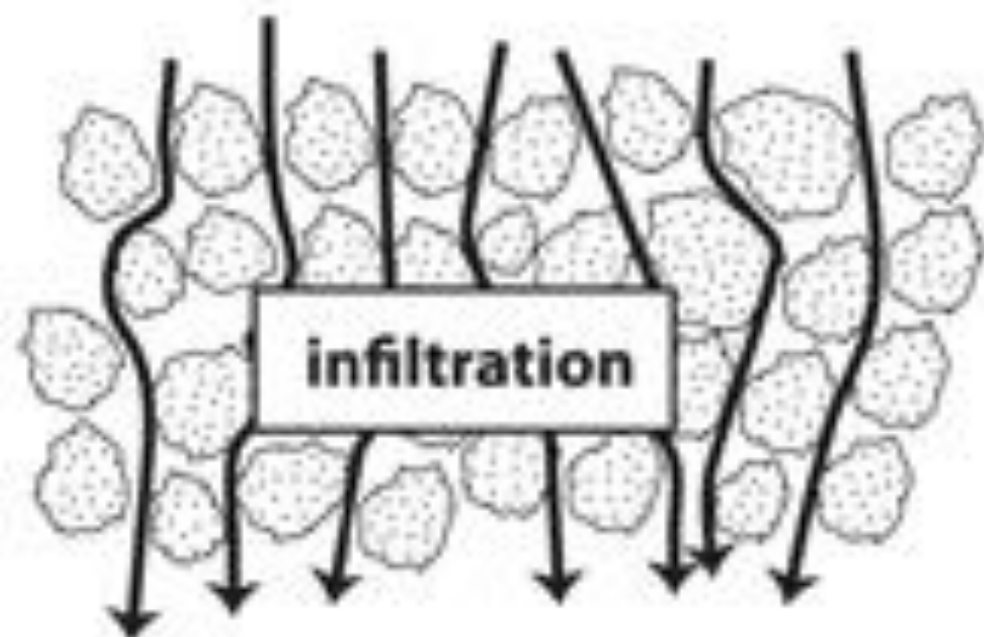

a) aggregated soil

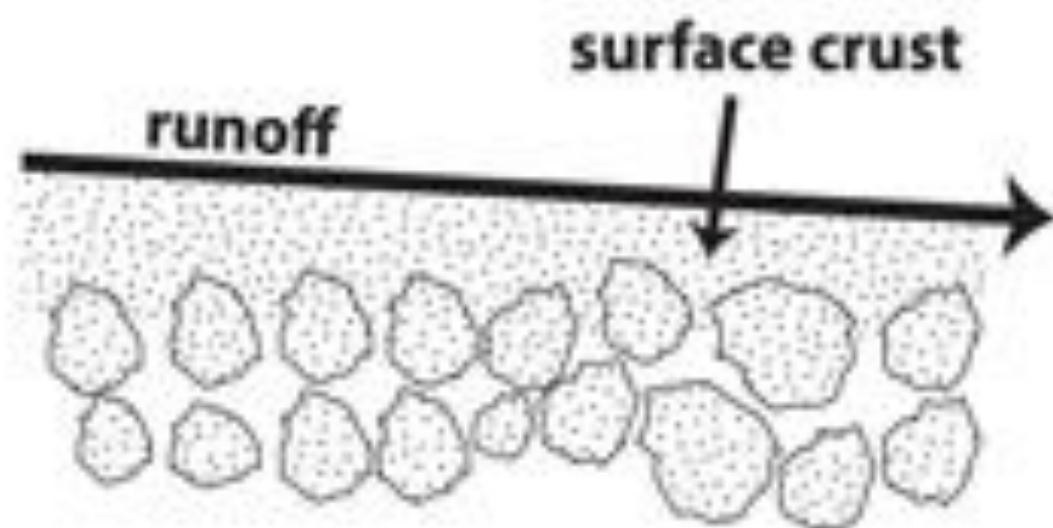

b) soil crusts over after aggregates break down



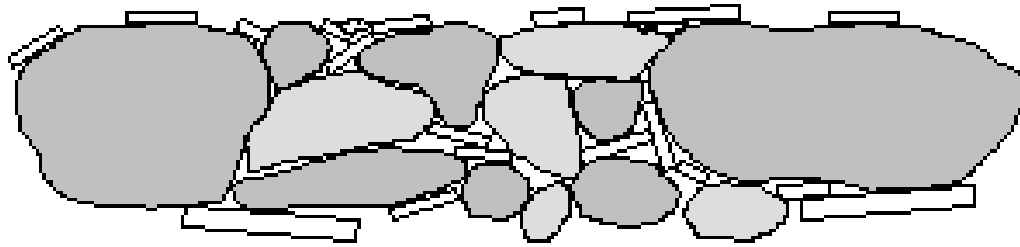

**Soil surface prior
to crusting
(0 rainfall events)**

Large neck pore

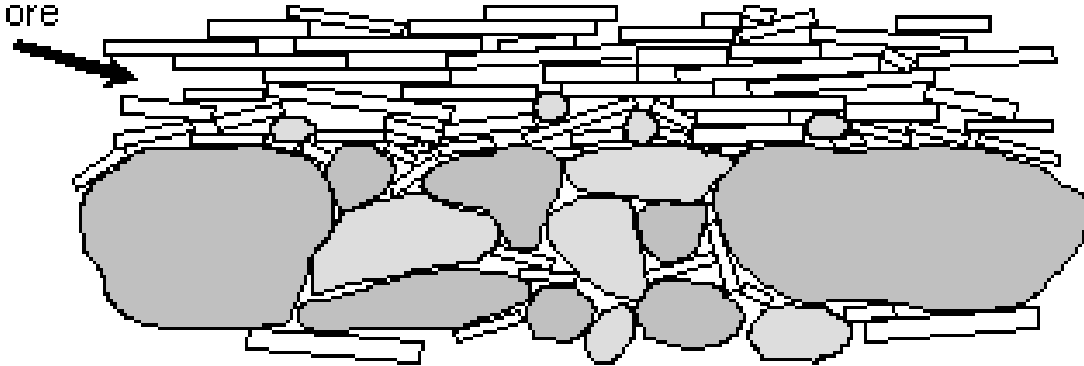

**Soil surface with
a depositional crust
(1 rainfall event)**

Small neck pore
in well-sorted
cover crust

Large packing pore
at interface of original
and new crust layers

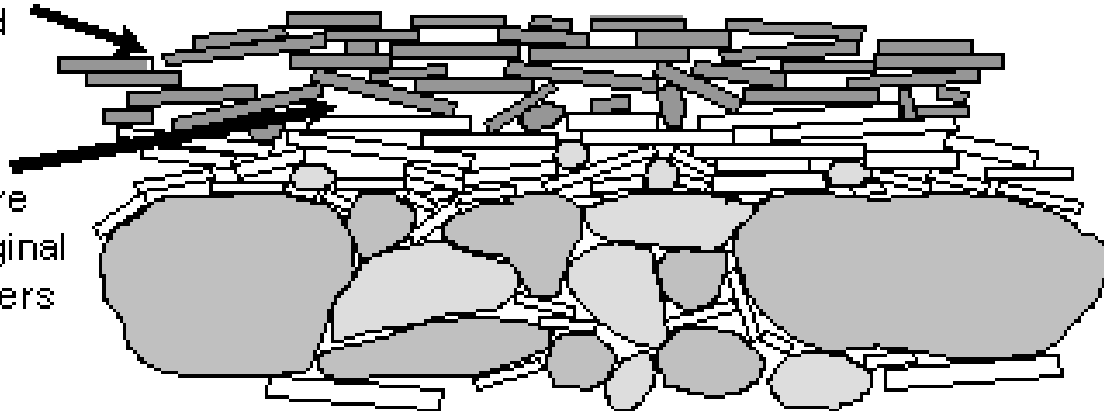

**Soil surface with
a depositional crust
and a "cover crust"
(2 rainfall events)**

Prevention and Remediation of Soils

- Consult the:
- the approved NPDES plan details, notes and sequence for prevention and remediation measures,
- the design engineer if necessary,
- a soil scientist or landscape architect
- the Conservation District.
- PA DEP E&S Manual and PCSM Manual for Best Practices.
- Penn State University soil testing lab for recommendations

Preventing Soil Crust Formation

- Design the infiltration bed to be on native topsoil, or keep the topsoil in place until the infiltration bed construction begins.
- Replace the topsoil as soon as possible to prevent the subsoil crust.
- Temporarily stabilize within 4 days.
- Add compost – the organic compounds stabilize soil aggregates.
- Add Gypsum or Quicklime to stabilize aggregates.
- Fertilize to promote vigorous vegetation for soil protection and macropore development.
- Mulch with 3 tons/acre straw mulch before next rain.
- Net and anchor mulch if necessary.





Soil Crust Remediation

- Gypsum – Calcium Sulfate – Ca SO_4
 - Inhibits dispersion of soil aggregates and crust formation
 - Preserves water infiltration rates
 - Reduces soil erosion
 - Promotes aggregate formation – remediates compaction

- Quicklime – CaO
 - Instantaneous increase in aggregates, especially in high clay content soils
 - 1800 lbs/acre
 - Soil tests should be completed first to get the correct rate
 - Limestone - CaCO₃ does not have this same immediate effect

Organic Amendments create healthy soil structure also

Topsoil Compaction

- Soil compaction can be caused by the force of construction equipment on the soil. The amount of force and the time determines compaction levels.
- Macropores are reduced when soil aggregates and root and fungal channels are broken by minimal force.
- Micropores are broken when clay particles are pushed down into sand particles with greater force.

The topsoil and subsoil compaction varies.

- The contact pressure determines the upper soil compaction.
- The axle load determines the amount of deep soil compaction.

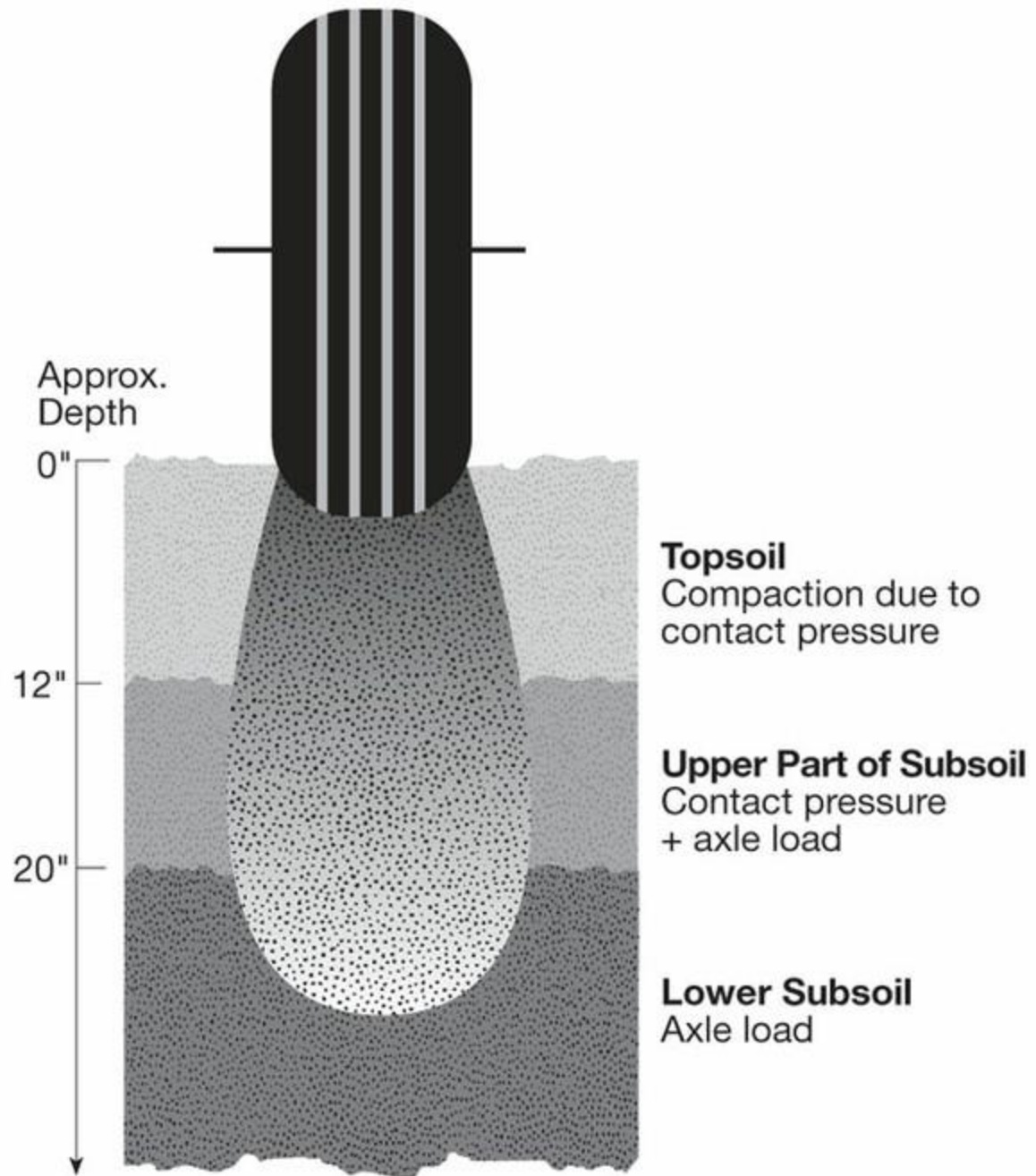

The axle load affects the upper and lower subsoils.

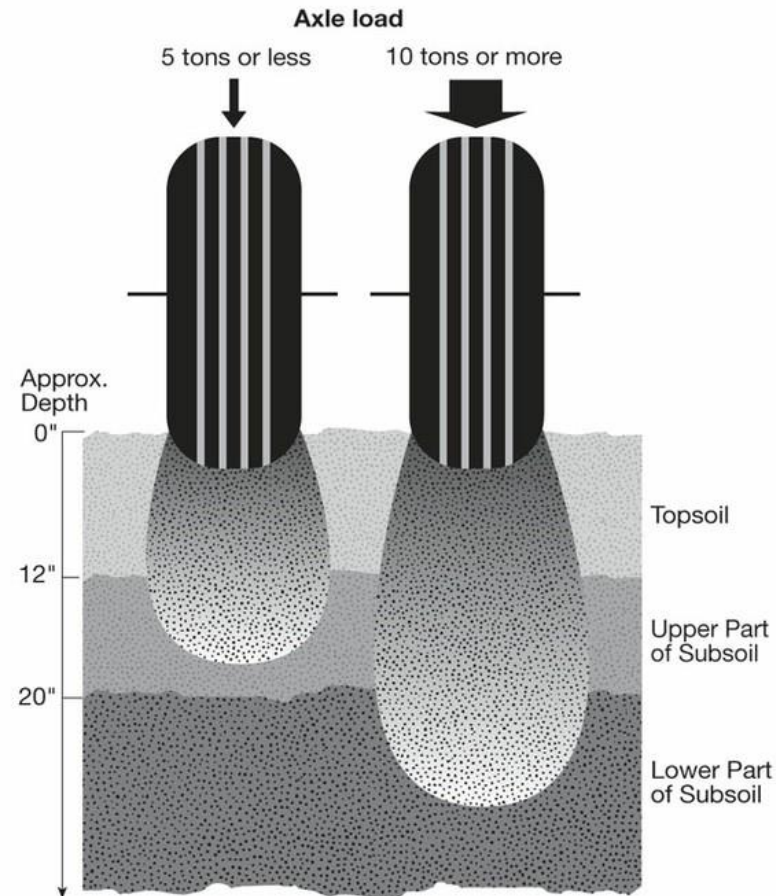

The contact pressure of the tires or tracks affects the topsoil and upper part of the subsoil.

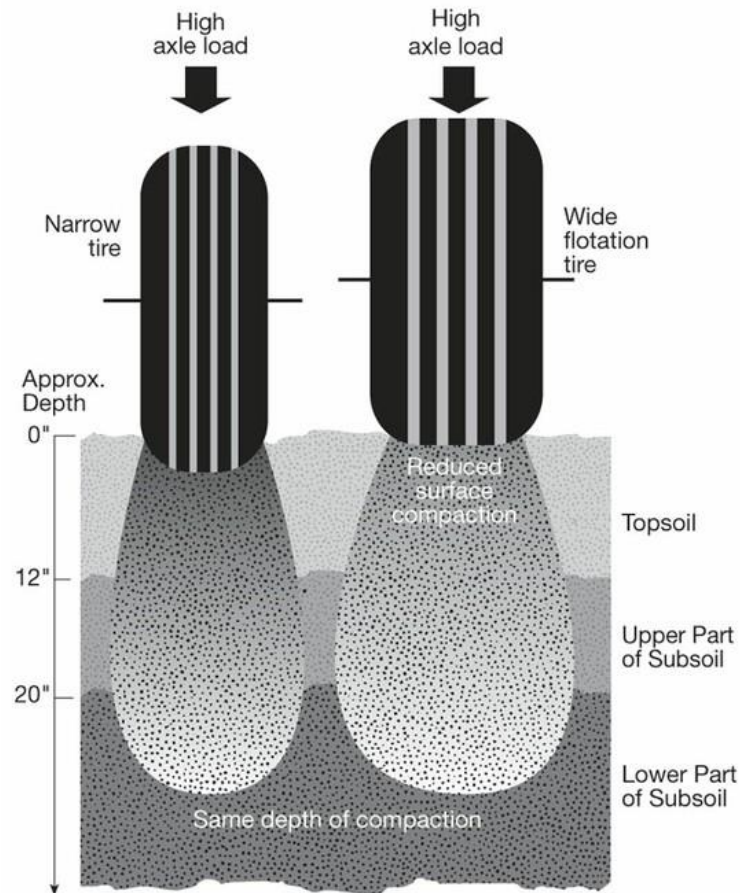

The effect of tires and tracks on pore spaces

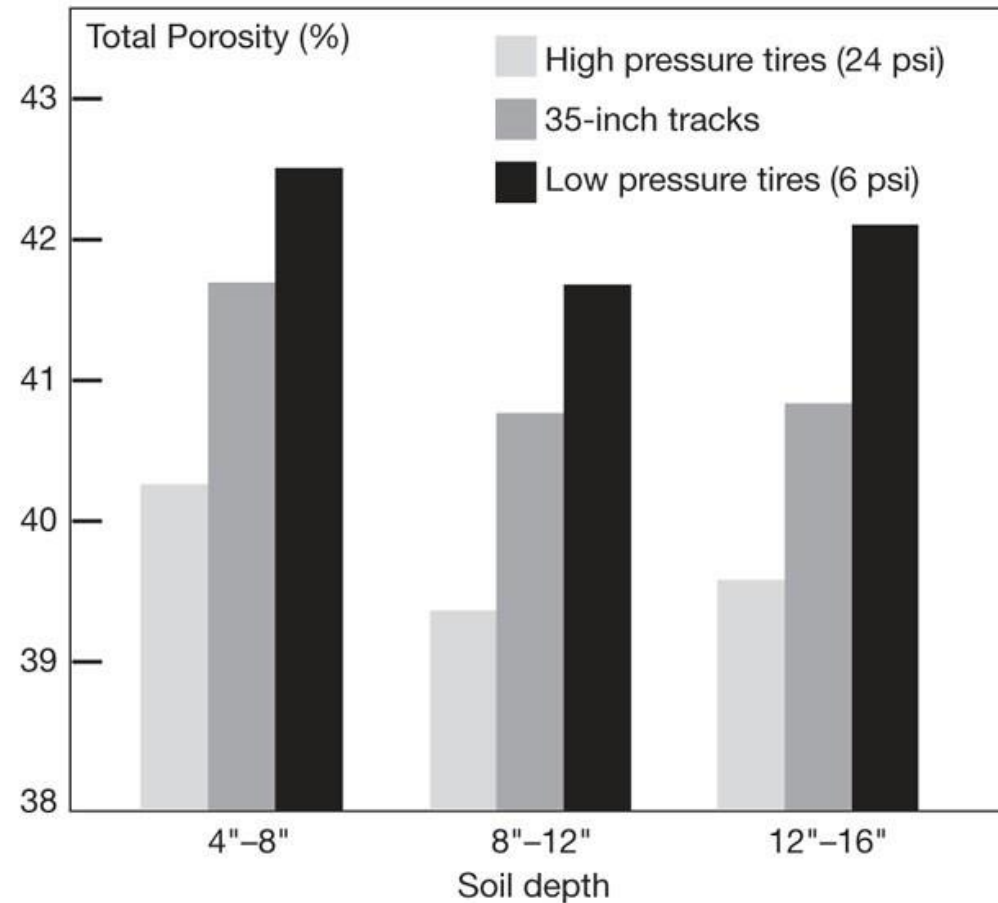

Wet soil has less strength and compacts more.

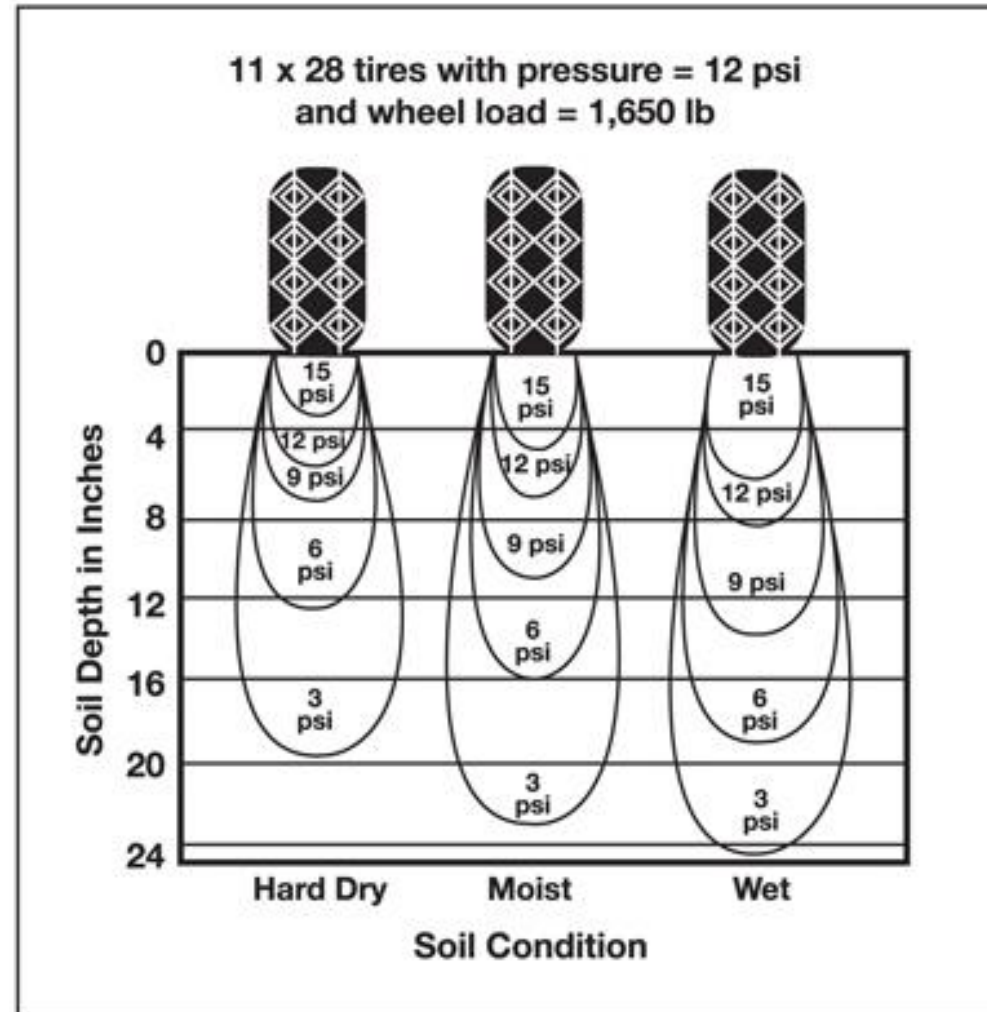

Compost installation equipment has significant weight



Construction Equipment Guide.com.

“Equipment Specs and Charts.” Retrieved from
<http://www.constructionequipmentguide.com/equipment-specs-and-charts>

Topsoil stockpiles compact the stored topsoil and the underlying soils



Preventing topsoil compaction

- Handle topsoil as little as possible.
- Use low tire pressure vehicles when driving on topsoil.
- Do not handle topsoil when wet.
- Temporarily seed within 4 days.
- Lime, fertilizer and matting are important to establish the grass and protect the granular structure and infiltration capacity of the soil.
- Repeat temporary stabilization to achieve 70% cover, if necessary.
- Replace topsoil as soon as possible to avoid pile compaction.

Avoid working in wet soils



Clay soils hold more water and remain wet longer.



Remediating Topsoil Compaction

- Obtain a soil test to determine the need for fertilizer, lime and organic amendments.
- Determine the depth of construction compaction and/or plow pan.
- Surface till in both direction to relieve compaction during dry conditions.
- Stabilize with grass. Temporary stabilization improves long term infiltration.
- Mulch with 3 tons/acre straw mulch.
- Install and anchor erosion control mat or netting if necessary.

Preventing Subsoil Compaction

- Use the lightest axle load equipment appropriate for the job.
- Keep tire pressures on the lower acceptable range of inflation.
- Establish a central travel lane for the site to keep the most compacted areas in proposed roadway or areas that can be remediated by ripping or subsoiling afterwards.
- Establish a parking area for heavy equipment and remediate this area afterwards.
- Keep equipment time and speed to an efficient level.
- Avoid driving equipment into infiltration areas. Work heavy equipment from the sides as much as possible. Use light equipment in the infiltration beds.

Infiltration basins and raingardens should not be intentionally compacted



Fence off areas that are marked Minimal Compaction



Remediating Compacted Areas

- Subsoil Compaction
 - Determine the depth and amount of compaction with a penetrometer.
 - Relieve compaction with a subsoiler or ripper set to 1" or 2" below the compaction depth. Subsoil or rip in a 2D grid.

Minnesota Stormwater Manual, Kees 2006







